



DMP-200 Digital Media Player Installation Manual

Rev: C
Date: 07 Dec 2006
Doc Number: DMP8012-00

AVIONICS INNOVATIONS, INC.
2450 Montecito Road
Ramona, CA 92065
Phone (760) 788-2602
Fax (760) 789-7098
www.avionicsinnovations.com

Revision History

Revision	Date	Description	By
A	26-July-06	Initial Release	SB
B	20-Oct-06	Updated Installation Kit Part Numbers Updates for V2.04 firmware <ul style="list-style-type: none">- PAUSE signal type- BUSY active selection- Test Ext Outputs- Test Ext Inputs Added Installation Checkout Procedure	SB
C	07-Dec-06	-Improved behavior of external Pause for better operation with cabin PA Systems	SB

Table of Contents

REVISION HISTORY	2
TABLE OF CONTENTS.....	3
1. INTRODUCTION.....	5
1.1 Description	5
1.2 Scope	5
1.3 Installation Kit	5
2.0 MECHANICAL	6
2.1 Specifications.....	6
2.2 Mounting Considerations.....	6
3.0 ELECTRICAL	6
3.1 General.....	6
3.2 Connection to Aircraft Power	6
3.3 Inputs	7
3.3.1 Remote Pause/Play Button.....	7
3.3.2 Discrete Triggers	8
3.3.3 Outputs.....	9
3.3.4 Audio.....	9
3.3.5 Discrete	9
3.4 Connector Pinouts.....	10
4.0 SETUP MODE	11
4.1 Entering and Exiting Setup Mode	11
4.1.1 Discrete Triggers 1 Through 3 – Active Level	11
4.1.2 External Pause – Active Level.....	11
4.1.3 External Chime Length	11
4.1.4 Display Brightness.....	11
4.1.5 “LOUD” Volume Level.....	12
4.1.6 PLAY Screen Text	12
4.1.7 External Pause Signal Type	12
4.1.8 Configuration of the BUSY Output.....	12
4.1.9 Test External Outputs.....	13
4.1.10 Test External Inputs.....	13

5.0	INSTALLATION CHECKOUT PROCEDURE	13
6.0	TROUBLESHOOTING AND ERROR MESSAGES	14
6.1	Troubleshooting	14
6.2	Error Messages	15
7.0	DRAWINGS	16
7.1	Mechanical Drawing	16
7.2	Electrical Interconnect	16

1. Introduction

1.1 Description

The DMP-200 Digital Media Player is a self-contained unit which stores and replays pre-recorded audio tracks. The audio tracks are encoded in "Motion Picture Expert Group (MPEG) Level 3" format, commonly referred to as "MP3". Audio files are stored in a removable CompactFlash™ memory card which is prepared and installed by the user.

Audio tracks are selected via a single rotary pushbutton on the front panel of the DMP-200. Optionally, the DMP-200 may be connected to a maximum of three external discrete trigger inputs, each of which can be configured in software to select a particular audio track.

The DMP-200 accepts a power input of between 10VDC and 35 VDC and provides a single pair of ground-referenced stereo line-level audio output signals. A Mono output which combines the Stereo line level outputs is also available.

The DMP-200 has been designed and tested to the Environmental Specifications of RTCA DO-160E. An Environmental Qualification Form which describes the various parameters and the levels to which they were tested is available upon request from Avionics Innovations.

1.2 Scope

This document describes the installation and initial checkout of the DMP-200 Digital Media Player. It may be used to support all installations, including those intended for initial Type or Supplemental Type Certification approvals and FAA Form 337 Field Approvals.

1.3 Installation Kit

Before beginning the installation, verify that the following items are present:

Qty	Part No.	Description
1	20000	Digital Media Player Main Unit
1	DMP200-20	DMP-200 Installation Kit, consisting of:
1	DMP1010-00	(1ea) Mounting Tray
	14046-00	(1ea) 16-pin Molex Connector
	14400-00	(16ea) Molex Contacts
	14073-00	(2ea) 4-40 X 3/8 Pan Head Screws for Molex Connector
	DMP057	(1ea) 256MB CompactFlash™ Memory Card
	DMP8012-00	(1ea) DMP-200 Installation Guide
	DMP8011-00	(1ea) DMP-200 Operators Guide
	DMP200-01	(1ea) DMP200 Card Prep Software
1	DMP058	(OPTIONAL) USB reader/writer for CompactFlash™ cards

2.0 Mechanical

2.1 Specifications

The DMP-200 is fully contained within a 2-inch (5cm) high standard mount enclosure.

Height:	2.00 in.	(5.1 cm)
Width:	6.25 in.	(15.8 cm)
Depth*:	4.34 in.	(11.0 cm)
Weight:	1.10 lb	(499 g) (With Mounting Tray)

Tray depth behind panel. Connector shell protrudes 0.25" (0.64 cm) beyond system enclosure.

2.2 Mounting Considerations

The DMP-200 should be installed in a normally heated, pressurized section of the aircraft; however the unit contains no moving parts and does not require special vibration isolation. The unit may be mounted in an auxiliary area of the instrument panel, in a pedestal, or anywhere in the aircraft cabin outside of the cockpit. In a severe vibration environment, the unit should **not** be mounted vertically with the front panel facing down, to ensure that the memory card does not accidentally vibrate loose. Otherwise, the DMP-200 may be installed in any orientation and at any angle.

3.0 Electrical

3.1 General

The following guidelines should be used when installing the DMP-200:

- ◆ All wiring to be installed in accordance with FAA AC-4313-1A, Chapter 11, Sect. 2
- ◆ All non-audio wiring to be MIL-W-22759 unless otherwise specified
- ◆ All audio wiring to be MIL-C-27500 shielded unless otherwise specified

3.2 Connection to Aircraft Power

The DMP-200 accepts a wide range of input voltage directly, without the need for converters or configuration changes.

Minimum input:	10.0 VDC	(1.0 Amp @ 10.0 VDC)
Maximum input:	35.0 VDC	(0.1 Amp @ 35 VDC)
Nominal input:	14 VDC / 0.30 Amp	
	28 VDC / 0.15 Amp	

Aircraft power must be supplied via a 1 Amp resettable circuit breaker.

3.3 Inputs

3.3.1 Remote Pause/Play Button

An external input is provided which can either emulate the front panel pushbutton, or can be used only to pause or resume playback. When set to “Edge-Activated”, the **Remote Pause/Play** input going active will immediately pause or resume the playback of any audio track in progress. In addition, if the knob has been turned so that a desired track is displayed (i.e. “queued up”), activating the Remote Pause/Play input will cause the track to begin playing. In these situations, the remote Pause/Play performs exactly like the front panel pushbutton.

This is especially useful in single-pilot helicopter applications. If the remote pushbutton is mounted on or near the cyclic, the pilot can control the audio without releasing the flight controls. After playback of each audio track, the DMP-200 display automatically “points” to the *next* track on the memory card. Thus, the pilot can simply press the remote button after each track to initiate playback of the next audio track.

The Remote Pause/Play input can be configured in Setup Mode as active high or active low. It can also be configured as either an “edge-activated” or a “level-activated” signal:

- **Edge-Activated**

When set to “edge-activated” (the default setting), the remote pushbutton works exactly like the front panel knob. Pause/Play function is toggled each time the signal changes from inactive to active, and new track playback may be started from the remote pushbutton as well. For example, if set up as Active Low, the Pause/Play will toggle each time a grounding pushbutton is pressed. Releasing the button has no effect.

- **Level-Activated**

This setting is intended for use when the remote Pause/Play input is connected to a cabin PA system’s KEY signal, to momentarily pause the DMP-200 playback while the PA is in use. If a track is playing, the DMP-200 will be PAUSED for as long as the Pause/Play signal is active, and will resume playing when the signal returns to inactive. If the DMP-200 is either idle or paused when the remote Pause/Play signal changes, it has no effect.

Like the discrete trigger inputs, Remote Pause/Play is floating and must be pulled up or down with an external resistor, depending on the desired active state. The input signal may vary between 0V and 35 VDC: levels above 3.5 VDC will be interpreted as “high”, while levels below 3.5 VDC will be “low”.

When Edge-Activated is selected, the Remote Pause/Play input works in parallel with the front panel knob – playback may be paused via one and resumed via the other. Unlike the front panel knob, however, playback mode cannot be cancelled by holding the Remote Pause/Play input active.

Like the discrete trigger inputs, Remote Pause/Play is floating and must be pulled up or down with an external resistor, depending on the desired active state. The input signal may vary between 0V and 35 VDC: levels above 3.5 VDC will be interpreted as “high”, while levels below 3.5 VDC will be “low”.

The Remote Pause/Play input works in parallel with the front panel knob – playback may be paused via one and resumed via the other. Unlike the front panel knob, however, playback mode cannot be cancelled by holding the Remote Pause/Play input active.

3.3.2 Discrete Triggers

Three discrete trigger inputs are provided, each of which can be assigned to a particular audio track via the CardPrep software. When a trigger input becomes active, the corresponding audio track is played. Each input can be configured independently in Setup Mode as active high or active low.

If more than one trigger input becomes active at the exact same time, the higher number input has priority. For example, if Trigger 3 and Trigger 1 become active simultaneously, the track assigned to Trigger 3 is played and Trigger 1 is ignored.

The trigger inputs are floating, and must be pulled up or down externally depending on the desired active state. Inputs may vary between 0V and 35 VDC: levels above 3.5 VDC will be interpreted as “high”, while levels below 3.5 VDC will be “low”.

Example: Active Low

The annunciator lamp functions as a pull-up resistor. If a lamp is not used, it must be replaced by a resistor (1/4 W, 10K to 47K Ohms)

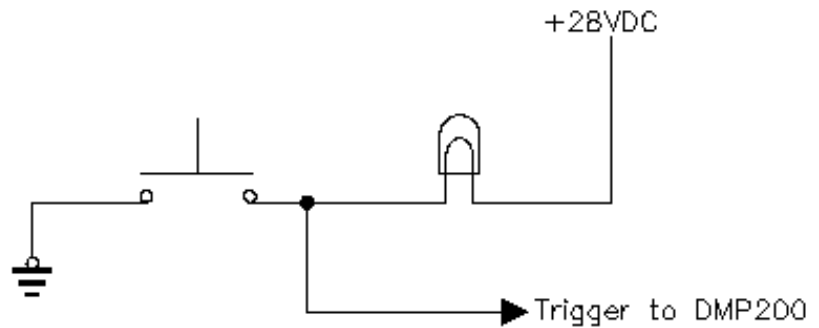

Example: Active High

The annunciator lamp functions as a pull-down resistor. If a lamp is not used, it must be replaced by a resistor (1/4 W, 10K to 47K Ohms).

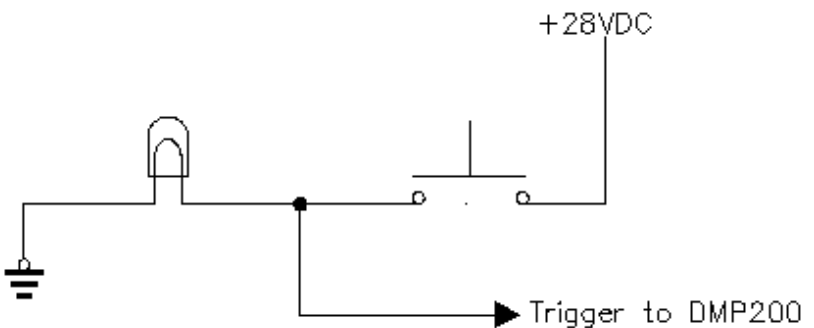

3.3.3 Outputs

3.3.4 Audio

The DMP-200's stereo audio and mono outputs are ground-referenced, line-level signals with a typical signal level of 1.8 V p-p. If isolation is required, an audio isolation transformer such as a Triad SP-50 or a Magna-Tek TY-141P must be provided externally. Volume level is selected from the front panel by the user, and stereo balance is selectable from setup mode.

3.3.5 Discrete

Two discrete outputs are provided for interfacing external equipment: CHIME and BUSY.

CHIME is provided for interfacing to an external chime tone generator. CHIME is an open-collector output capable of sinking 1 Amp, with a maximum input voltage of 35 VDC.

CHIME goes active when a speech track has been selected or triggered, but the actual playback does not begin until CHIME goes inactive. The length of time CHIME remains active is selected in Setup Mode. CHIME can be used to enable an external chime or tone generator, to announce the fact that a speech message is about to begin. CHIME does not go active when a music track has been selected.

By default, BUSY is active anytime the DMP-100 is producing audio. However, the installer may configure BUSY to go active only for speech tracks, only for music tracks, for all types of tracks, or even to never go active at all. BUSY can be used to drive an audio switching relay, enable an external amplifier, or even to light a remote annunciator. This selection is done in SETUP mode.

3.4 Connector Pinouts

Pin	Name	Description
1	PWR	Aircraft power, 10-35 VDC
2	AUDL	Audio output, left channel
3	SPARE1	Reserved
4	TRIG3	External trigger input 3
5	TRIG2	External trigger input 2
6	TRIG1	External trigger input 1
7	AUDR	Audio output, right channel
8	PWR	Aircraft power, 10-35 VDC
A	Reserved	Not Used
B	PAUSE	External PAUSE/PLAY input
C	AGND	Audio Ground
D	AGND	Audio Ground
E	BUSY	BUSY output, open collector, 0.5A max
F	CHIME	CHIME output, open collector, 1A max
H	MONO	Mono Audio Output
J	GND	Aircraft power return

4.0 Setup Mode

4.1 Entering and Exiting Setup Mode

Setup Mode is entered via the following steps:

1. Turn the unit off.
2. Depress and hold the front panel knob.
3. Switch the unit on while continuing to hold in the front panel knob.
4. Release the knob **when the display first lights up**. After the 5-second intro screen, the first Setup Mode item is displayed.

Setup Mode is exited by simply cycling power on the unit.

Turning the knob once Setup Mode has been entered allows selection of the following setup items:

4.1.1 Discrete Triggers 1 Through 3 – Active Level

The current active level of each of the three discrete triggers, TRIG1 through TRIG3 is displayed. Pushing the front panel knob toggles each between “ACTIVE HIGH” and “ACTIVE LOW”. The new settings are immediately written to permanent memory – no explicit “save” action is required.

4.1.2 External Pause – Active Level

The current active level of each of the external PAUSE input is displayed. Pushing the front panel knob toggles each between “ACTIVE HIGH” and “ACTIVE LOW”. The new setting is immediately written to permanent memory – no explicit “save” action is required.

4.1.3 External Chime Length

The CardPrep software offers the user the option of activating an external chime prior to playing a speech track. The “EXT CHIME LENGTH” setup item determines how long the unit waits, with the CHIME signal asserted, before de-asserting the CHIME signal and playing the speech track. Pushing the front panel knob cycles EXT CHIME LENGTH from 0 to 9 seconds.

CardPrep also offers the option of an “internal” chime, which is simply a selected MP3 file (usually a recording of a chime of some type) that is played before each speech track. Note that if a card specifies an internal chime, the CHIME output is not activated.

4.1.4 Display Brightness

The DMP-200’s display can be set to one of eight brightness levels. Each push of the front panel knob cycles through a brightness level between 12.5% and 100%. Set this to a level appropriate to the expected cockpit lighting conditions.

4.1.5 “LOUD” Volume Level

The playback volume level is normally set by turning the front panel knob while holding the knob pushed in. However, the CardPrep software allows the user to designate any track to be played at a “LOUD” volume setting. This is normally applied to speech tracks such as important safety messages. For example, if the DMP-200 is playing background music and the operator has set the volume to an unobtrusive level, the safety message can be played at a higher volume and the previous volume level will be restored when the music resumes.

This setup item allows you to select the volume level which will be set if a track is played which has the “LOUD” volume attribute enabled. Pressing the front panel knob will start playback of a sample speech track, which loops continuously. Turning the knob will adjust (and display) the volume setting which will then be retained as the “LOUD” volume level.

The “LOUD” volume setting is also used when an internal chime is played.

4.1.6 PLAY Screen Text

The DMP-200 can display one of two types of screens while an audio track is playing. The default is an elapsed time display which shows the length of time the track has been playing. The second type of display is “Prompts” which cycle through helpful suggestions of user interface options. Each push of the front panel knob toggles between the selections of each type of display.

4.1.7 External Pause Signal Type

The external Play/Pause input signal can be treated as either an “EDGE” or a “LEVEL”. If “EDGE” is selected, the play/pause function will toggle each time the external button is pressed-and-released. If “LEVEL” is selected, the DMP-200 will remain paused as long as the external button is held down, and will resume when the button is released.

Press the button to toggle between “EDGE” and “LEVEL”. The factory default value is “EDGE”.

4.1.8 Configuration of the BUSY Output

The BUSY Output can be configured to go active under one of the following conditions:

- Any time a SPEECH track is playing
- Any time a MUSIC track is playing
- Any time a track is playing, regardless of the track type (factory default value)
- BUSY never goes active

Press the button to cycle through these choices. When the desired choice is displayed, simply cycle power to the DMP-200 or select a different SETUP category.

4.1.9 Test External Outputs

This page allows the installer to cycle through all the DMP-200 external outputs, setting and clearing each one in turn. This function is used during the installation checkout procedure, and may be used any time an external output needs to be tested. Each press of the button will activate one output and clear all others. Except the “All OFF” selection, which turns off all outputs.

4.1.10 Test External Inputs

This page allows the installer to test the three external trigger inputs and the external Play/Pause input. The display shows which input, if any, is currently active. If more than one input is active, the display will show only the highest priority input. Play/Pause is the highest priority, followed Triggers 3 through 1 in descending order.

If an input appears to have the wrong polarity, be sure the active levels are set correctly (see page 11 for more information on setting active levels for inputs).

5.0 Installation Checkout Procedure

After all wiring is double-checked, especially the power and ground connections, the following procedure should be performed to verify external connections:

1. Press and hold the button while turning on power. Release the button when the DMP-200 display first lights up.
2. The DMP-200 will be in SETUP mode. Advance through all the setup items as described above, and set the options to match your installation. Do NOT select the setup item: “Set LOUD volume level” unless you have a memory card installed that has been prepared using the supplied CardPrep software.
3. Turn the knob to display the SETUP item labeled “Test Ext Outputs”. Press the button repeatedly to cycle through the various external outputs. Confirm that all attached equipment (annunciators, relays, chime generators, etc) perform as intended.
4. Turn the knob to display the SETUP item labeled “Text Ext Inputs”. For each input (triggers and external Pause/Play), activate the external contact closure and confirm the corresponding display on the DMP-200.

To verify the audio outputs, you must prepare a memory card using CardPrep software before powering up the DMP-200. Power up the DMP-200 normally (do not enter SETUP mode), and select a track for playback to create an audio signal for testing.

6.0 Troubleshooting and Error Messages

6.1 Troubleshooting

Here are a few common problems and their potential causes:

Symptom	Possible Causes/Solutions
No audio, even though display shows track playing.	<ul style="list-style-type: none">• Volume turned down. Last volume setting is retained between power cycles, and previous user may have turned volume way down. Push-and-turn knob to change volume.• Invalid MP3 file used. The DMP200 will not play MP3-PRO, MP4 (AAC), WAV or WMF files.• MP3 file recorded at an extremely low volume level. Try playing the file on a PC to make sure it is audible.
External triggers do not work, or a track triggers repeatedly.	<ul style="list-style-type: none">• Incorrect active levels selected. Each trigger must be configured to be active high or active low, depending on the installation. Refer to Section 3.3.2 for details.• Trigger inputs were not installed with pull-up or pull-down resistor. One or the other must be present, depending on the installation. Refer to Section 3.3.2 above for details.
Display is too bright or too dim.	<ul style="list-style-type: none">• The display is set to one of eight levels of brightness at installation. This selection cannot be changed in normal operation. It must be changed from SETUP mode. Refer to Section 4.1.4 above for details.
Tracks being played do not match the description on the display.	<ul style="list-style-type: none">• In CardPrep, "Update Settings Only" was selected on the Create Card tab even though MP3 tracks were changed. This button may only be used when items such as Triggers and Attributes have changed, but not the actual MP3 tracks. Regenerate the card using the Create Card button.

6.2 Error Messages

In addition, the DMP-200 may display the following error messages:

Display	Meaning	Possible Causes
Invalid Card, no firmware.	The firmware update file, "0000.hex", cannot be opened on the CompactFlash card.	<ul style="list-style-type: none"> The card was not prepared using DMP200 CardPrep software The card was created for a DMP100
Invalid Card, no MP3 config.	The MP3 configuration file, "0000.xd3", cannot be opened on the CompactFlash card.	<ul style="list-style-type: none"> The card was not prepared using DMP200 CardPrep software The card was created for a DMP100
Internal error number XX	A fault has occurred between the two internal processors of the DMP200.	Contact Avionics Innovations. Please record the error number shown on the display.
Memory Card Not Inserted!	The DMP200 is not detecting the presence of a CompactFlash card.	<ul style="list-style-type: none"> No card is inserted The card is defective The card is not fully seated

7.0 Drawings

7.1 Mechanical Drawing

7.2 Electrical Interconnect

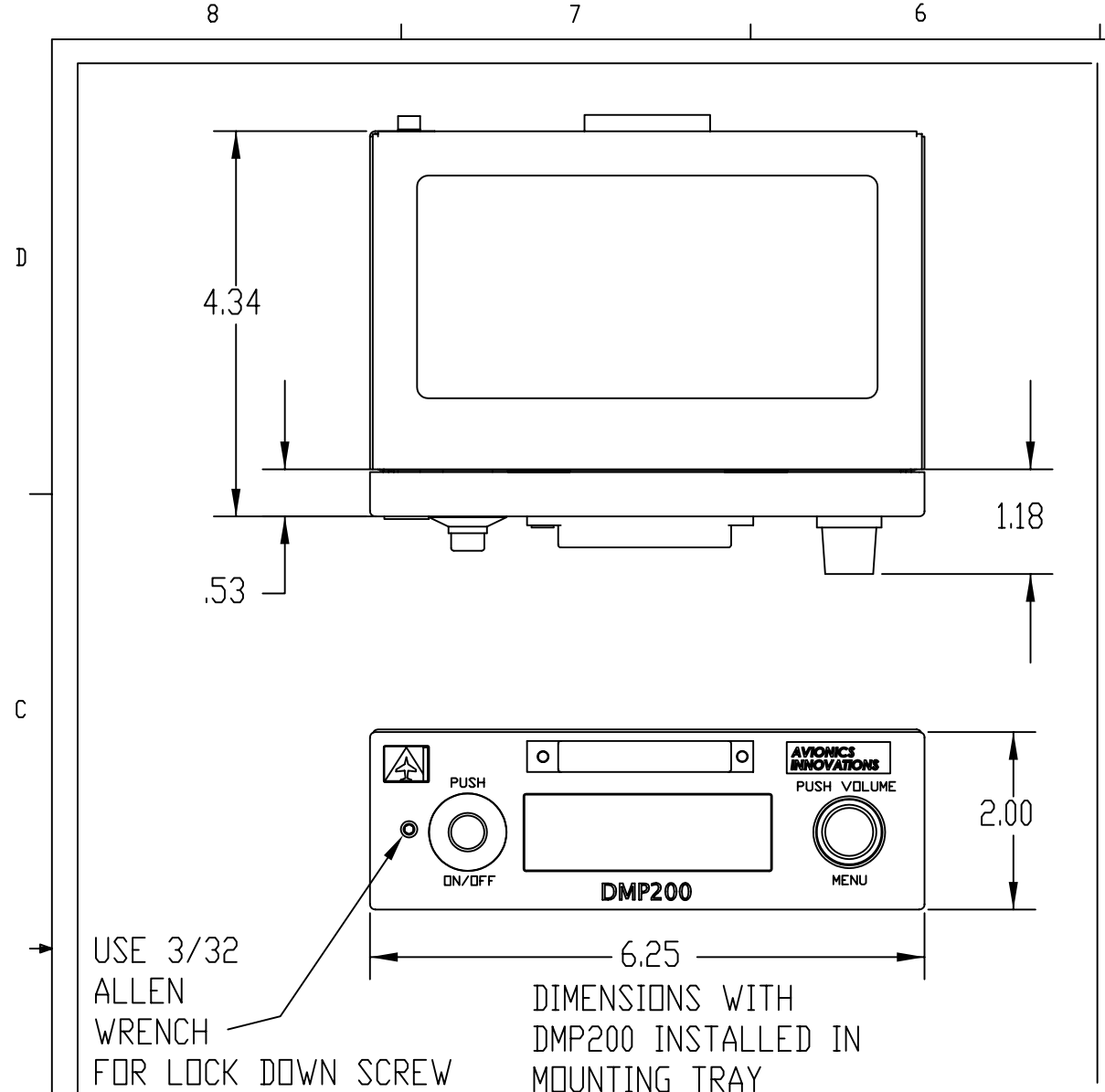

MATERIAL INFORMATION

DMP200-00 (MP3 Player), P/N 20000
 Bezel: Aluminum, 6061-T6.
 Finish: Anodize or as specified.
 Outer Case: 5052-H32 Aluminum, 0.04 Thick.
 Finish: Chem Film, Color: Gold or to Spec
 Weight: 0.9 lbs or 0.40 kg

Mounting Tray, P/N DMP1010-00
 Aluminum, 5052-H32. 0.032 Thick.
 Finish: Chem Film, Clear.
 Weight: 0.2 lbs or 0.10 kg

REVISIONS				
ZONE	REV.	DESCRIPTION	DATE	APPROVED
	A	INITIAL RELEASE	4/3/06	
	B	Added Weight to Spec on Unit and Tray	5/26/06	
	C	Added Unit and Tray Part Numbers	6/14/06	
	D	Added View of J1 in Tray	6/23/06	

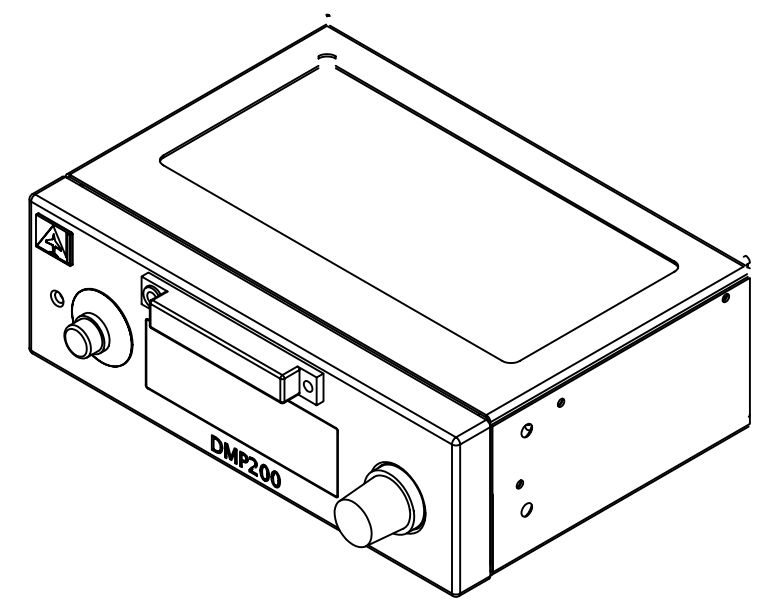
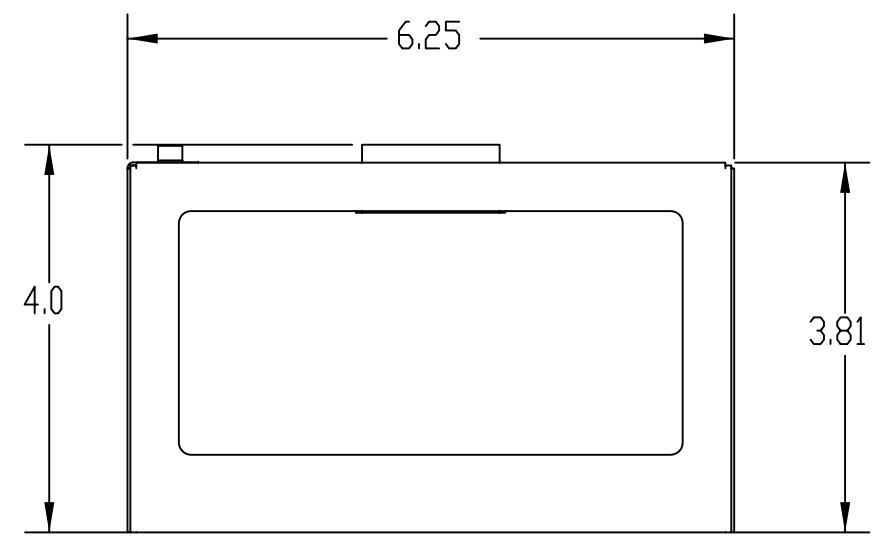

ISOMETRIC VIEW
 DMP200 INSTALLED
 IN MOUNTING TRAY

DMP200 MOUNTING TRAY
 TOP VIEW

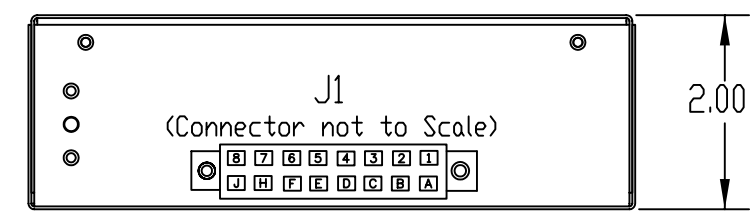
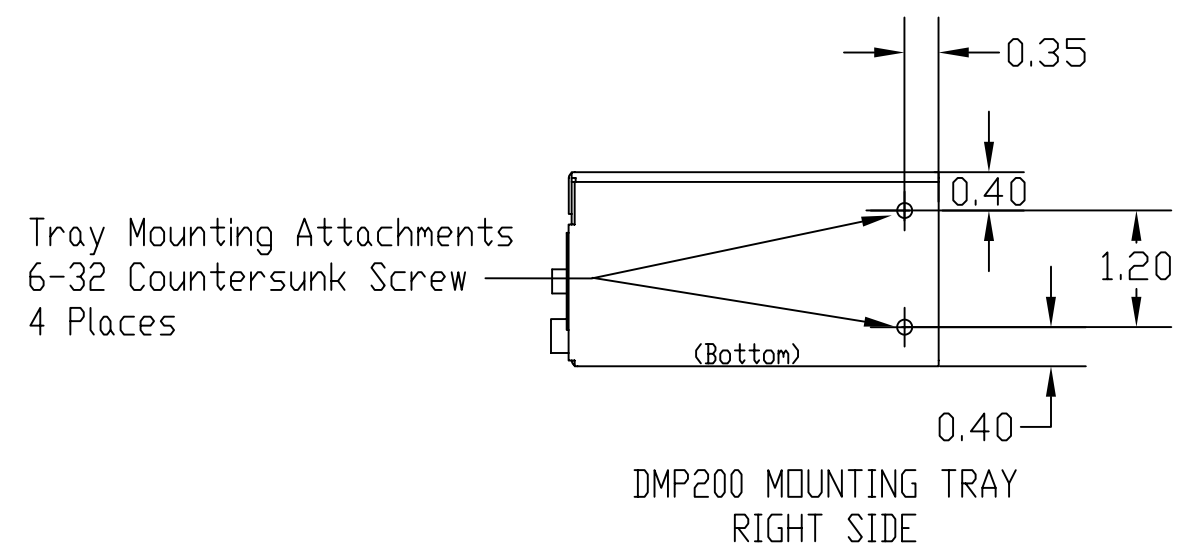

DMP200 MOUNTING TRAY
 FRONT VIEW

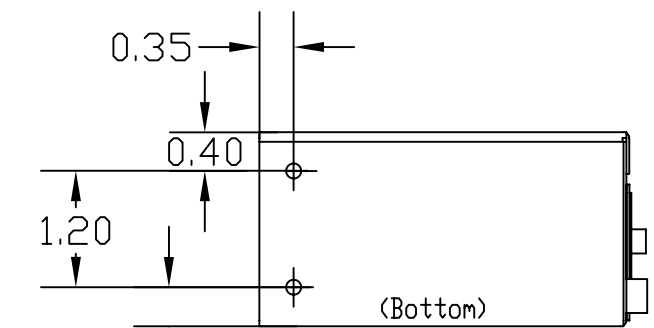

DMP200 MOUNTING TRAY
 LEFT SIDE

UNLESS OTHERWISE SPECIFIED:		DATE	NAME	Avionics Innovations
DIMENSIONS ARE IN INCHES		DRAWN	3/28/06	
TOLERANCES:		CHECKED	4/03/06	Mahan
FRACTIONAL ±		ENG APPR.		
ANGULAR: MACH ±		MFG APPR.		
BEND ±		Q.A.		
± .01		COMMENTS:		
± .005				
INTERPRET GEOMETRIC TOLERANCING PER:				
MATERIAL	--			
FINISH	--			
TITLE: DMP200-00 MOUNTING CONFIGURATION				
SIZE B	DWG. NO. DMP8010-00	REV D		
SCALE: 1:2	WEIGHT:	SHT 17 OF 18		

PROPRIETARY AND CONFIDENTIAL
 THE INFORMATION CONTAINED IN THIS DRAWING IS THE SOLE PROPERTY OF AVIONICS INNOVATIONS. ANY REPRODUCTION IN PART OR AS A WHOLE WITHOUT THE WRITTEN PERMISSION OF AVIONICS INNOVATIONS IS PROHIBITED.

